

3 PANEL STACKER DOOR

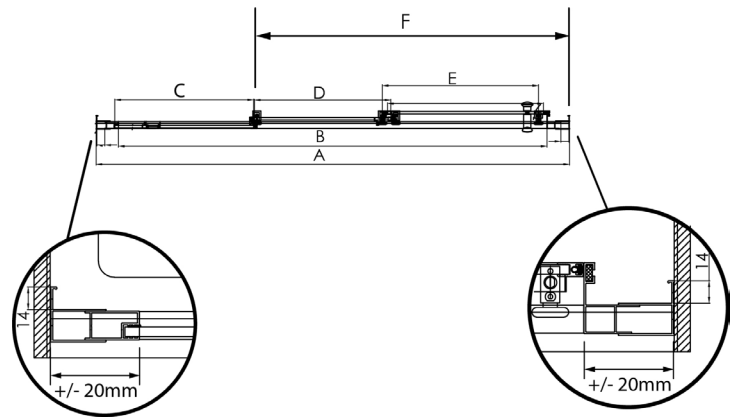

Pictured above - 3 Panel Stacker Door Silva



DESCRIPTION

The Symphony 3 Panel Stacker Door can be purchased on its own and is a perfect door replacement when renovating an existing Alcove Shower.

A Return Panel can also be added to create a custom 2 Sided Shower.

FEATURES

- Internal slider
- Door is reversible and can open left to right or right to left
- Standard heights 1950mm/1830mm
- No door swing out into the bathroom dripping water onto the floor
- Water drains back into the shower
- Door panels go behind the bottom extrusion
- No splash-back out the bottom of the shower door
- Low profile extrusion to and bottom to hold wheels
- Approx 15mm adjustment allowing for out of plumb walls
- Stylish chrome handle
- New roller assembly ensures greater reliability and smooth functionality
- 6mm Safety Glass compliant to AS/NZS2208
- Silva finish only

LEGEND

| Dimension | Description | Door Size | | |
|-----------|-----------------------------|-----------|--------|--------|
| | | 900mm | 1000mm | 1200mm |
| A | Maximum Outside Frame Width | 880mm | 980mm | 1180mm |
| B | Internal Frame Width | 768mm | 868mm | 1068mm |
| C | Fixed Panel Width | 246mm | 280mm | 346mm |
| D | Centre Sliding Panel Width | 240mm | 273mm | 340mm |
| E | Outer (handle) Panel Width | 289mm | 322mm | 288mm |
| F | Door Opening Dimension | 417mm | 484mm | 617mm |

ORDERING CODES

| Product Description | SKU | | |
|--|------------------|-------------------|-------------------|
| | 900mm | 1000mm | 1200mm |
| Door Only Silva (LH/RH Reversible) 1830mm High | D3PS900SI18SYMP | D3PS1000SI18SYMP | D3PS1200SI18SYMP |
| Door Only Silva (LH/RH Reversible) 1900mm High | D3PS900SI195SYMP | D3PS1000SI195SYMP | D3PS1200SI195SYMP |

WARRANTY INFORMATION

All bathroomware products supplied by Fibre Systems carry our Quality Assurance and Product Warranty. We use the highest quality materials available and manufacture these in accordance with New Zealand specifications and requirements to ensure that all products are fit for the intended purpose for which they are designed. Our customer's peace of mind is of paramount importance to us.

Warranty Periods

| | |
|--------------------------------------|----------|
| Baths | 10 years |
| Showers | 10 years |
| Shower Screens and Doors | 10 years |
| Silva and White Coatings | 10 years |
| E-Line + Squareline + Dezine Showers | 5 years |
| Black Coatings | 5 years |
| Aquaknight Easy Clean Wastes | 7 years |
| Accessories | 2 years |



Warranty Exclusions

The product must be installed according to the instructions supplied.

The water supply temperature applied to the product must not exceed 55 degrees Celsius.

All cleaning and cleaning products must be in accordance with our cleaning instructions and guidance.

Commercial Applications (where products are installed in a building where occupancy is via a commercial arrangement i.e. a rental property, hotel, hostel etc) are restricted to a 2 year warranty on all products.

CLEANING AND MAINTENANCE

Please refer to our cleaning instructions document for guidance - available on our website.